

POHL'AD ZHORA M 1:50

TOP ELEVATION
OBERANSICHT

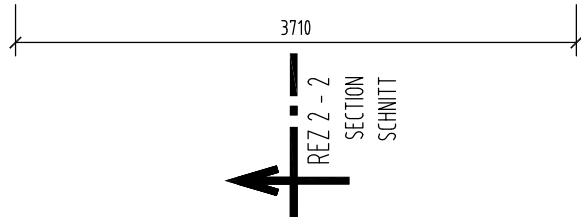
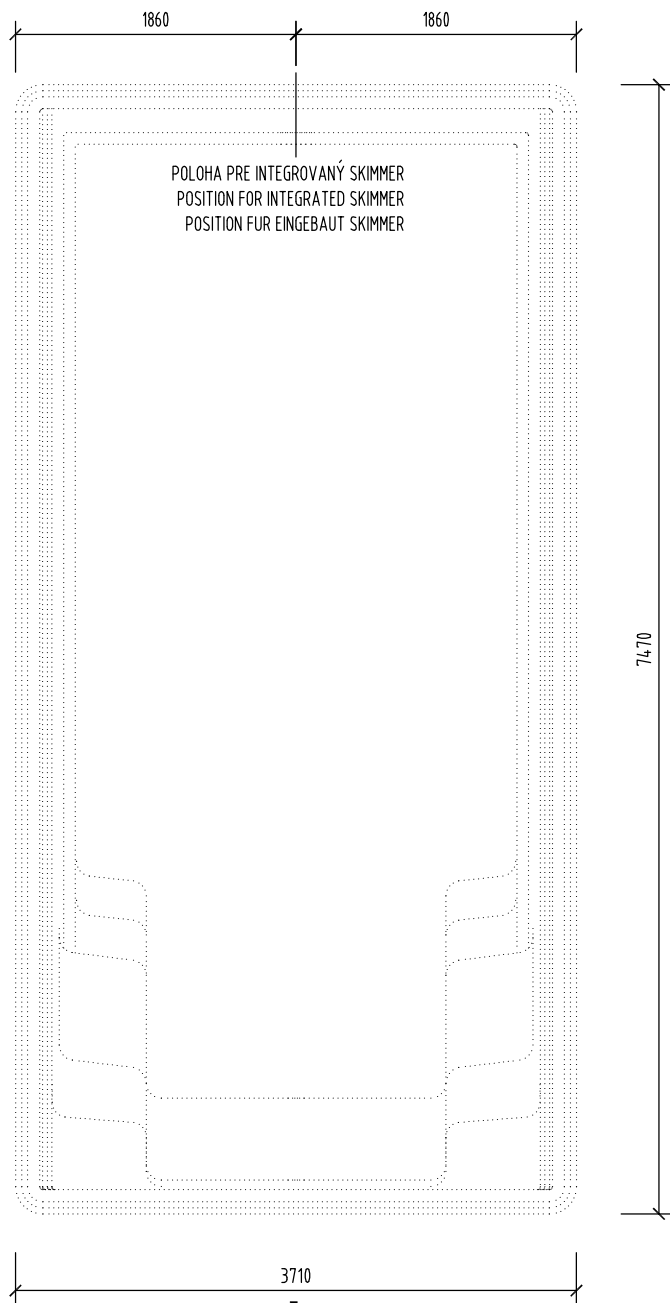

REZ 1-1 M 1:50

CROSS SECTION
QUERSCHNITT

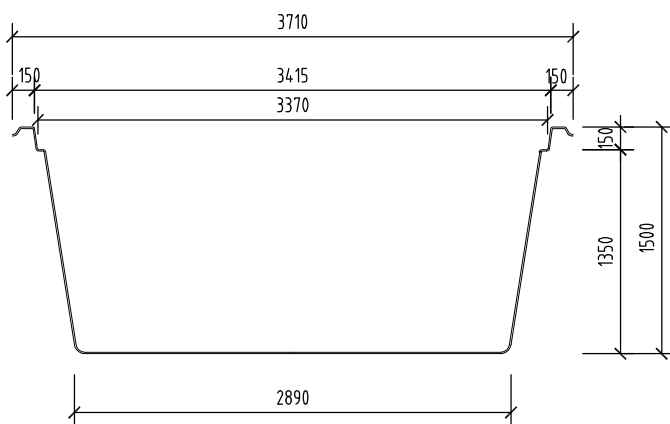

REZ SCHODOV M 1:50

CROSS SECTION FOR STAIRS
QUERSCHNITT FÜR TREPPE

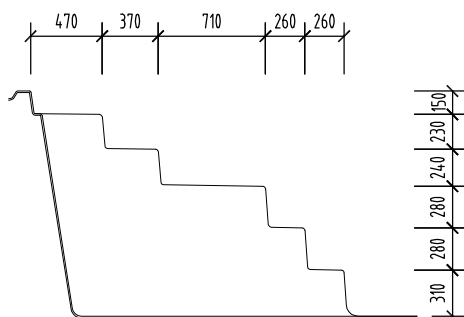

REZ 2-2 M 1:50

LONGITUDINAL SECTION
QUERSCHNITT

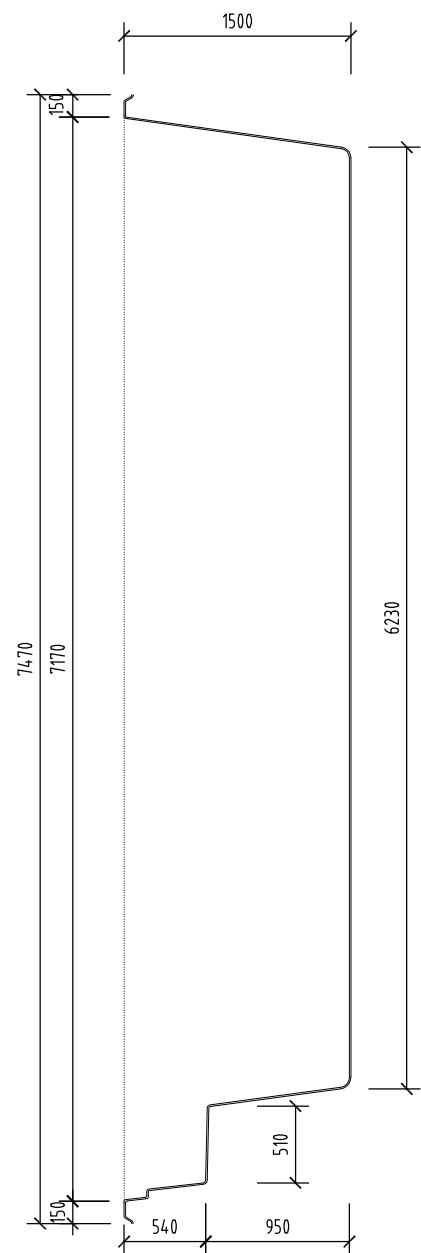

DETAIL ÚPRAVY PRE ROLETU M 1:25

DETAIL FOR ROLLER
DETAIL FÜR ROLLADEN

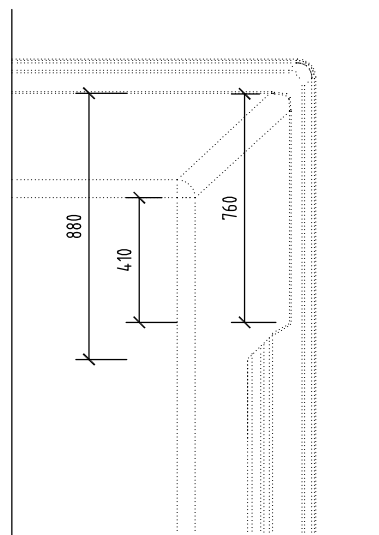

POZNÁMKA / NOTE / ANMERKUNG:

HRÚBKA STENY BAZÉNA JE CCA. 10 MM
TOLERANCIA PRESNOSTI ± 10 MM.

THICKNESS OF THE SIDEWALL OF SWIMMING POOL IS APPROX. 10 MM.
MEASURED WITH TOLERANCE RATE ± 10 MM

DIE SCHWIMMBADWAND DÜCKE IS CA. 10 MM.
BECKENTOLERANZ IST ± 10 MM.

POOL HIGH FOR CONTAINER FOR SEA TRANSPORT IS 3570MM.

DETAIL ÚPRAVY INTEGROVANÝ SKIMMER M 1:25

DETAIL FOR INTEGRATED SKIMMER
DETAIL FÜR EINGEBAUT SKIMMER

FIXÁCIA PLAVÁKU HLADINY
FIXATION FOR WATER LEVEL FLOAT
ELEMENT FIXIERUNG FÜR WASSERHOHE

D63 NAPOJENIE SANIA SKIMMERA
D63 SKIMMER-SAUGANSCHLUSS
D63 SKIMMER-OUTLET FITTING

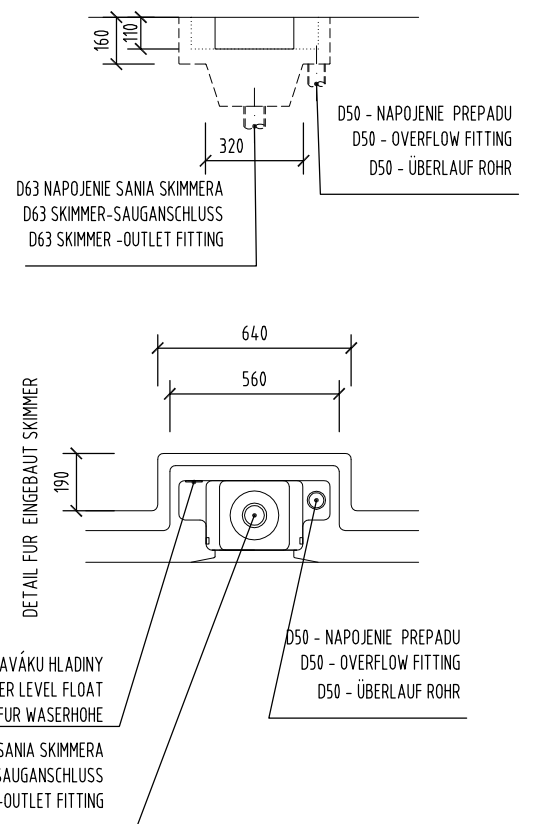

NÁZOV VÝKRESU:
DRAWING NAME:
ZEICHNUNG NAME:

FUN 74S
GEOMETRIA BAZÉNA
GEOMETRY OF SWIMMING POOL
SCHWIMMBAD GEOMETRIE

COMPASS
enjoy the moment

www.compasspools.eu

KRESLIL: DRAWN BY / ZEICHNER:	ING. PETER KALETA	DÁTUM: DATE / DATUM:	08/2020
MIERKA: SCALE/MASSTABE:	1:50	FORMÁT DRAWING FORMAT / ZEICHNUNG FORMAT:	A3
VERZIA: VERSION:	1	ČÍSLO DRAWING NUMBER: ZEICHNUNG NUMBER:	1