

POHLAD ZHORA M 1:50

TOP ELEVATION
OBERANSICHT

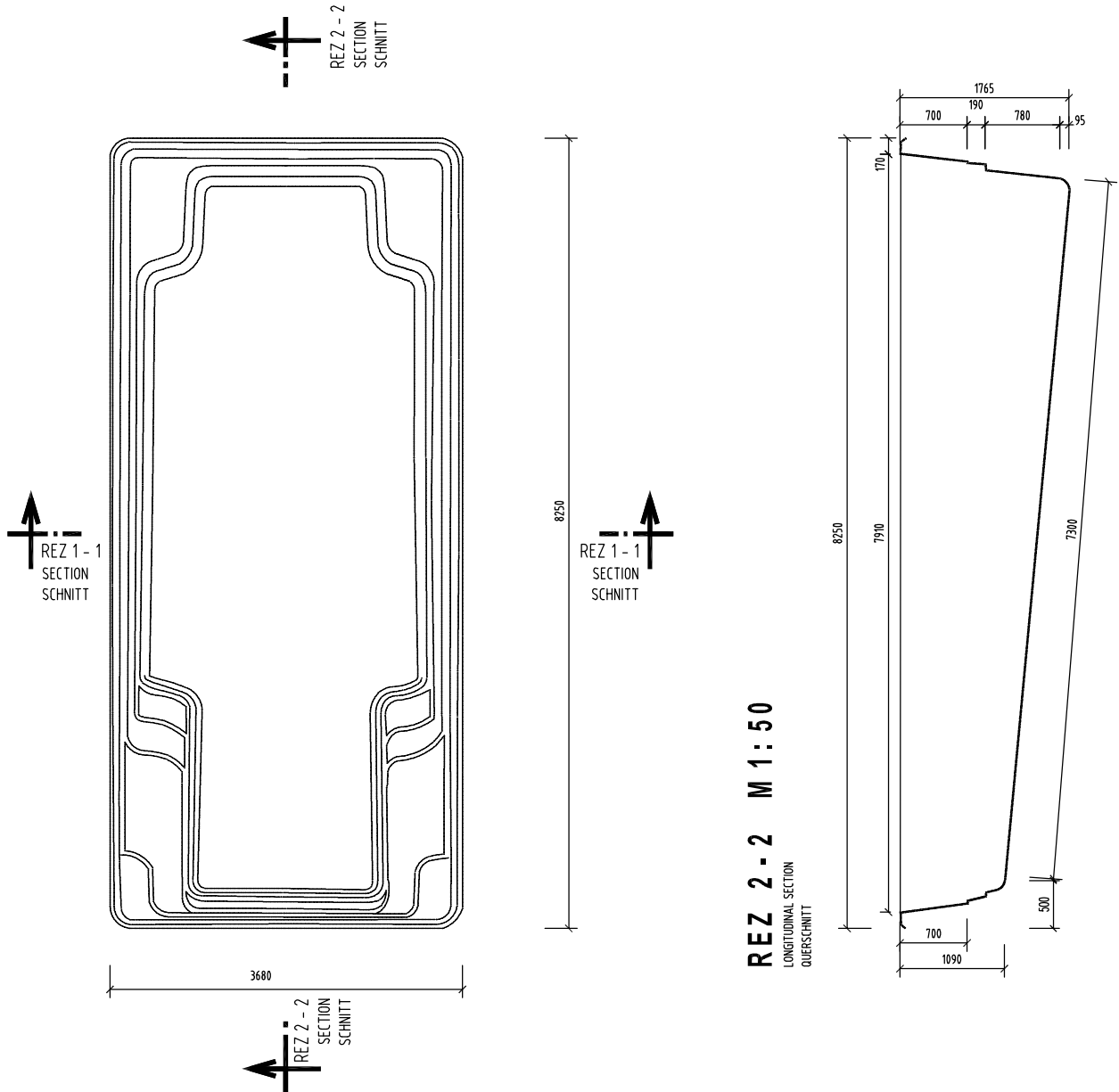

REZ 1 - 1 M 1:50

CROSS SECTION
QUERSCHNITT

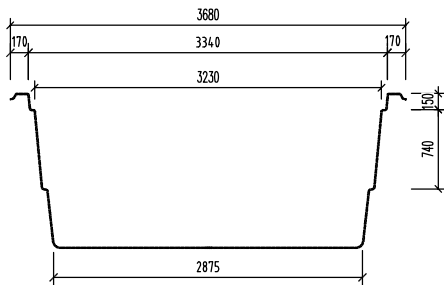

POZNÁMKA / NOTE / ANMERKUNG:

HRŮBKA STĚNY BAZÉNA JE CCA. 10 MM
TOLERANCIA PRESNOSTI 7 - 10 MM

THICKNESS OF THE SIDEWALL OF SWIMMING POOL IS APPROX. 10 MM.
MEASURED WITH TOLERANCE RATE 7 - 10 MM

DIE SCHWIMMBADWAND DÜCKE IS CA. 10 MM.
DUCKENTOLERANZ IST 7 - 10 MM.

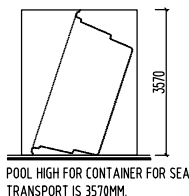

POOL HIGH FOR CONTAINER FOR SEA
TRANSPORT IS 3570MM.

NÁZOV VÝKRESU:
DRAWING NAME:
ZEICHNUNG NAME:

X-TRAINER 82
GEOMETRIA BAZÉNA
GEOMETRY OF SWIMMING POOL
SCHWIMMBAD GEOMETRIE

COMPASS 
enjoy the moment

www.compasspools.eu

KRESLIL: DRAWN BY / ZEIGNER:	ING. PETER KALETA	DÁTUM: DATE / DATUM:	01/2023
MIERKA: SCALE/MASSTABE:	1:50	FORMÁT DRAWING FORMAT / ZEICHNUNG FORMAT:	A3
VERZIA: VERSION:	3	ČÍSLO DRAWING NUMBER:	1