

# POHLAD ZHORA M 1:50

TOP ELEVATION  
OBERANSICHT

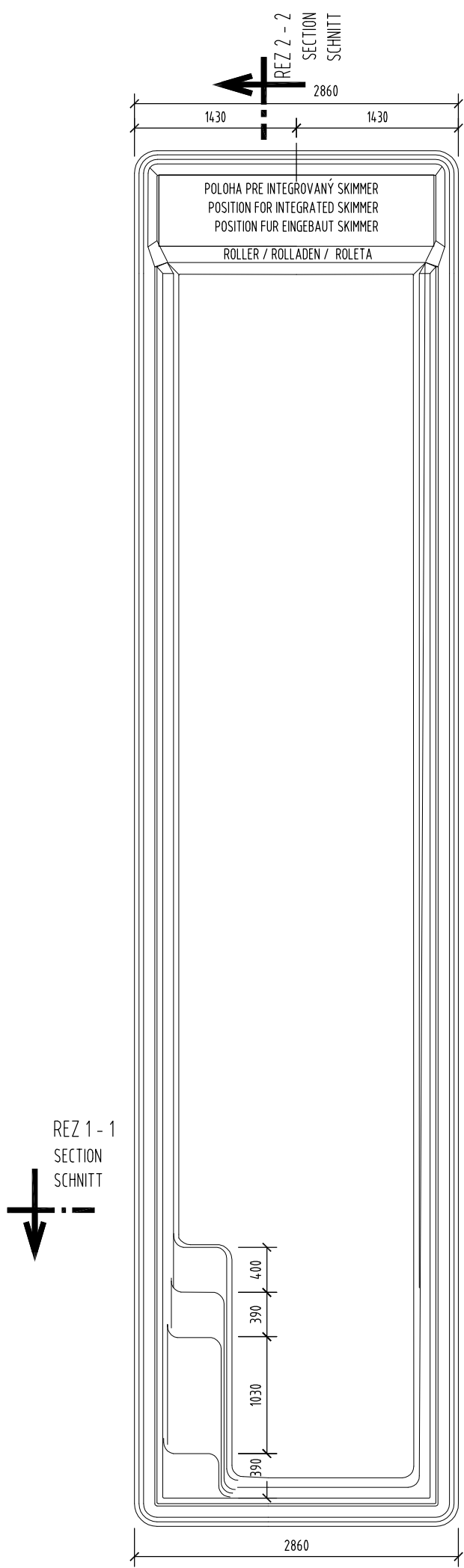

REZ 1 - 1  
SECTION  
SCHNITT

12170

REZ 1 - 1  
SECTION  
SCHNITT

## REZ 1 - 1 M 1:50

CROSS SECTION  
QUERSCHNITT

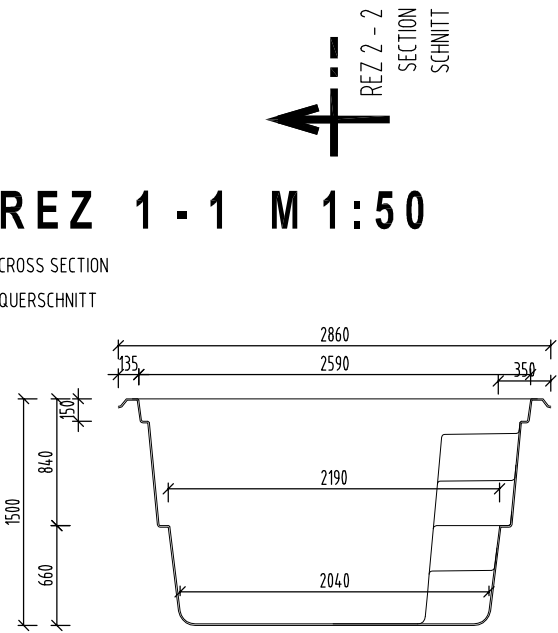

POZNÁMKA / NOTE / ANMERKUNG :

HRÚBKA STENY BAZÉNA JE CCA. 10 MM  
TOLERANCIA PRESNOSTI 7 - 10 MM

THICKNESS OF THE SIDEWALL OF SWIMMING POOL IS APPROX. 10 MM.  
MEASURED WITH TOLERANCE RATE 7 - 10 MM

DIE SCHWIMMBADWAND DÜCKE IS CA. 10 MM.  
DUCKENTOLERANZ IST 7 - 10 MM.

POOL HIGH FOR CONTAINER FOR SEA TRANSPORT IS 2750MM.

## REZ 2 - 2 M 1:50

LONGITUDINAL SECTION  
QUERSCHNITT

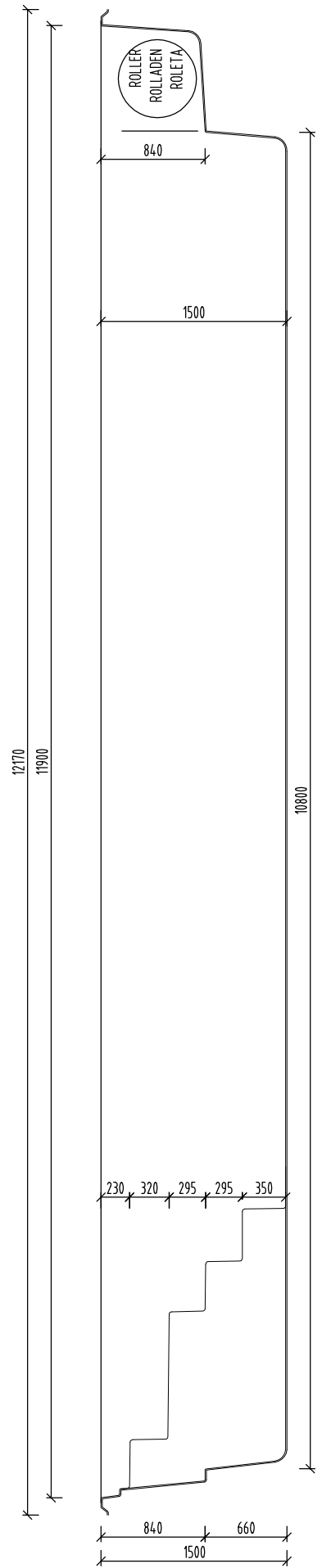

## DETAIL ÚPRAVY M 1:25 INTEGROVANÝ SKIMMER

DETAIL FOR INTEGRATED SKIMMER  
DETAIL FÜR EINGEBAUT SKIMMER

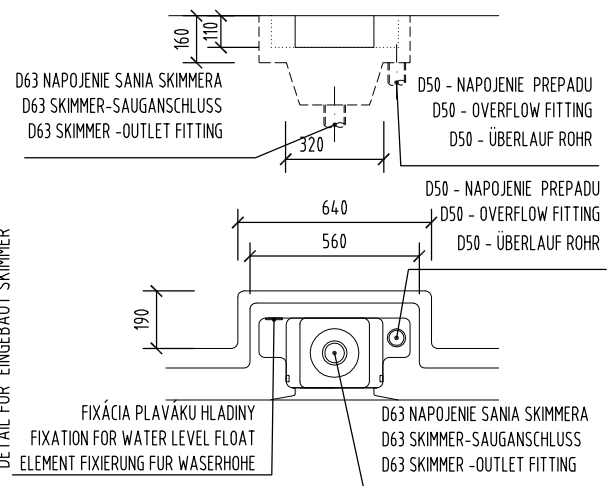

NÁZOV VÝKRESU:  
DRAWING NAME:  
ZEICHNUNG NAME:

**XL -FASTLANE 12.2**  
**GEOMETRIA BAZÉNA**  
**GEOMETRY OF SWIMMING POOL**  
**SCHWIMMBAD GEOMETRIE**

**COMPASS**  
*enjoy the moment*

[www.compasspools.eu](http://www.compasspools.eu)

KRESLIL: DRAWN BY / ZEICHNER:	ING. PETER KALETA	DÁTUM: DATUM / DATUM:	08/2020
MIERKA: SCALE/MASSTABE:	1:50	FORMÁT DRAWING FORMAT / ZEICHNUNG FORMAT:	A3
VERZIA: VERSION: VERSION:	2	ČÍSLO DRAWING NUMBER: ZEICHNUNG NUMBER:	<b>1</b>